

# KeyWarrior 8 LED

USB Keyboard Controller with LED Matrix  
Supplement to the KeyWarrior Data Sheet

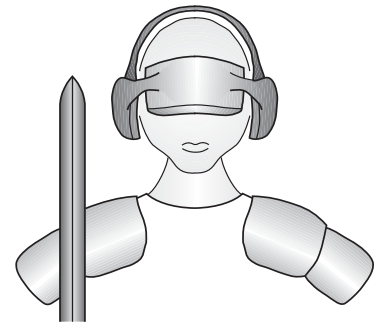

**Code Mercenaries**

## 1. Features

- USB low speed interface
- Full USB V1.1/2.0 compliance
- Full USB HID 1.1 compliance
- Supports up to 64 keys in 8x8 matrix
- Supports up to 64 LEDs in a 8x8 matrix with few external components, LEDs controllable via USB
- Supports diodes in the key matrix
- User defineable keyboard layout
- In system programmable keymap
- Custom chips with ROM based keymap for volume production
- Operator variant supports up to eight functions on every key
- Cell variant allows 16 keys to step through 3 different codes like on a cell phone
- Assignable function shift keys to switch to a second and third matrix table
- Direct drive for Caps lock, Num lock and Scroll lock LEDs
- Low cost ceramic resonator
- Single +5V power supply
- Low power consumption: 40mA max.
- Available in 48 pin SSOP (DIL40 for prototyping available, not recommended for production)

### 1.1 Variants

KeyWarrior 8 LED is available in Flex, Operator and Cell variants. Customer specific variants with ROM based key tables are available too.

#### KeyWarrior 8 FLEX LED

- One code per key
- Three matrix levels (two FN keys)

#### KeyWarrior 8 OPERATOR LED

- Eight codes per key
- Three matrix levels (two FN keys)

#### KeyWarrior 8 CELL LED

- 48 keys with 8 codes per key
- Three matrix levels (two FN keys)
- 16 keys with "Cell Phone" function, if pressed repeatedly while any FN key is down these keys step through three different codes

## 2. Functional Overview

The KeyWarrior 8 LED family is a branch of the KeyWarrior family. It is primarily designed for applications where some or all keys need indicator lights. Though other designs, like backlighting or displays, are possible too.

In addition to the 8x8 key matrix, which offers functions identical to the standard KeyWarrior 8 family, KeyWarrior 8 LED has the necessary control lines to drive a 8x8 LED matrix connected via two external shift registers. Since USB is the only keyboard interface that allows direct control of the LED function the KeyWarrior 8 LED offers only USB and not PS/2.

# KeyWarrior 8 LED

---

## Content

1 Features	1
1.1 Variants	1
2 Functional Overview	1
2.1 Product Selection Matrix	3
3 Pin Configurations	4
4 Pin Descriptions KeyWarrior 8 xxx LED DIL 40	5
4.1 Pin Descriptions KeyWarrior 8 xxx LED SSOP 48	6
4.2 Pin Descriptions	7
4.3 Flex, Operator, and Cell external EEPROM	7
4.4 EEPROM potential problem	7
5 Device Operation	9
5.1 Power Up	9
5.2 Keyboard Scanning	9
5.3 Key Rollover	9
5.3.1 Phantom Keys	9
5.4 Protocol Details	9
5.5 Controlling the LED matrix	9
6 Custom Scancode Tables	10
6.1 Function Shift Keys	10
6.2 Programming a Flex, Operator, or Cell Controller	10
6.3 KeyWarrior Operator Key Definitions	10
6.4 KeyWarrior 8 Cell LED Key Definitions	10
7 DC Characteristics	11
7.1 AC Characteristics	11
7.2 Absolute Maximum Ratings	12
8 Ordering Information	13
8.1 Shipping info	13
8.2 DIL 40 going obsolete	13
8.3 USB VendorID and ProductID	13
9 Typical Application for KeyWarrior 8 Flex LED, Controller Part, SSOP48	14
9.1 Typical Application for KeyWarrior 8 Operator/Cell LED, Controller Part, SSOP48	15
9.2 Typical Application for KeyWarrior 8 LED, Controller Part, SSOP48	16
9.3 Typical Application for LED matrix part	17
10 Package Dimensions	18
11 ESD Considerations	19
11.1 EMC Considerations	19
12 Revision History	19
13 RoHS compliance	19
Legal Stuff	19

# KeyWarrior 8 LED

## 2.1 Product Selection Matrix

Type	Matrix	FN-Keys	Mouse	ext. EEPROM	Codes per key	DIL40	SSOP48	Standard Part *
KeyWarrior 8 LED	8x8	2	-	-	1	√***	√	-
KeyWarrior 8 Flex LED	8x8	2	-	24C02	1	√***	√	√
KeyWarrior 8 Operator LED	8x8	2	-	24C16	8	√***	√	√
KeyWarrior 8 Cell LED	8x8	2	-	24C16	1/8 **	√***	√	√

\*) Standard parts are available with no setup cost or minimum order quantities. The non-standard parts may be subject to a setup charge as well as minimum order quantities.

\*\*) KeyWarrior 8 Cell LED does support 48 keys in Operator mode (8 codes per key) and 16 keys in cell phone mode. Cell phone mode keys do have a single code per key, but when used while any FN key is down they step through 3 different single codes.

\*\*\*) DIL40 is going to be discontinued, it is no longer recommended for new designs, however it is available for prototyping and short term production.

# KeyWarrior 8 LED

## 3. Pin Configurations

**KeyWarrior 8FlexLED-P  
KeyWarrior 8OperatorLED-P  
KeyWarrior 8CellLED-P  
40 Pin PDIP**

D+	1	40	Vcc
D-	2	39	GND
PowerOn	3	38	NC
NC	4	37	NC
SDA	5	36	CapsLED
NumLED	6	35	ScrollLED
X7	7	34	X6
X5	8	33	X4
X3	9	32	X2
X1	10	31	X0
SCL	11	30	NC
NC	12	29	NC
/OE	13	28	Strb
Clk	14	27	Data
Y7	15	26	Y6
Y5	16	25	Y4
Y3	17	24	Y2
Y1	18	23	Y0
PullToGND	19	22	XOut
GND	20	21	XIn

**KeyWarrior 8LED-P  
40 Pin PDIP**

D+	1	40	Vcc
D-	2	39	GND
PowerOn	3	38	NC
NC	4	37	NC
NC	5	36	CapsLED
NumLED	6	35	ScrollLED
X7	7	34	X6
X5	8	33	X4
X3	9	32	X2
X1	10	31	X0
NC	11	30	NC
NC	12	29	NC
/OE	13	28	Strb
Clk	14	27	Data
Y7	15	26	Y6
Y5	16	25	Y4
Y3	17	24	Y2
Y1	18	23	Y0
PullToGND	19	22	XOut
GND	20	21	XIn

**KeyWarrior 8FlexLED-S  
KeyWarrior 8OperatorLED-S  
KeyWarrior 8CellLED-S  
48 Pin SSOP**

D+	1	48	Vcc
D-	2	47	GND
PowerOn	3	46	NC
NC	4	45	NC
SDA	5	44	CapsLED
NumLED	6	43	ScrollLED
X7	7	42	X6
X5	8	41	X4
X3	9	40	X2
X1	10	39	X0
SCL	11	38	NC
NC	12	37	NC
/OE	13	36	Strb
Clk	14	35	Data
NC	15	34	NC
NC	16	33	NC
Y7	17	32	Y6
Y5	18	31	Y4
Y3	19	30	Y2
Y1	20	29	Y0
NC	21	28	NC
NC	22	27	NC
PullToGND	23	26	XOut
GND	24	25	XIn

**KeyWarrior 8LED-S  
48 Pin SSOP**

D+	1	48	Vcc
D-	2	47	GND
PowerOn	3	46	NC
NC	4	45	NC
NC	5	44	CapsLED
NumLED	6	43	ScrollLED
X7	7	42	X6
X5	8	41	X4
X3	9	40	X2
X1	10	39	X0
NC	11	38	NC
NC	12	37	NC
/OE	13	36	Strb
Clk	14	35	Data
NC	15	34	NC
NC	16	33	NC
Y7	17	32	Y6
Y5	18	31	Y4
Y3	19	30	Y2
Y1	20	29	Y0
NC	21	28	NC
NC	22	27	NC
PullToGND	23	26	XOut
GND	24	25	XIn

All drawings: TOP VIEW!

# KeyWarrior 8 LED

## 4. Pin Descriptions KeyWarrior 8 xxx LED DIL 40

Name	I/O	Type	Pins	Description
D+, D-	I/O	special	1, 2	USB differential data lines
PowerOn	I	internal Pull Up	3	Power Key input, pull high on power on
Data	O	CMOS	27	Data out to LED shift register
Clk	O	CMOS	14	Clock to LED shift register
Strb	O	CMOS	28	Strobe to LED shift register
/OE	O	CMOS	13	Driver enable for LED shift register
CapsLED	O	OD, 16mA	36	Drives Caps Lock LED, active low
NumLED	O	OD, 16mA	6	Drives Num Lock LED, active low
ScrollLED	O	OD, 16mA	35	Drives Scroll Lock LED, active low
X[7:0]	I	input, internal Pull Ups	7, 34, 8, 33, 9, 32, 10, 31	Matrix row lines. Inputs to controller
Y[7:0]	O	OD	15, 26, 16, 25, 17, 24, 18, 23	Matrix column lines. Periodically driven to low by the controller to scan the matrix.
SCL	O	CMOS	11	SCL line for external EEPROM (Flex, Op, Cell)
SDA	I/O	OD, internal Pull Up	5	SDA line for external EEPROM (Flex, Op, Cell)
NC	-	-	5, 11	Unused pin, do not connect (KeyWarrior 8 LED)
NC	-	-	4, 12, 29, 30, 37, 38	Unused pin, do not connect
PullToGND	I		19	Used during manufacturing, connect to GND
GND		Power supply	20, 39	Ground
Vcc		Power supply	40	Supply voltage
XOut	O		22	On chip oscillator output
XIn	I		21	On chip oscillator input

# KeyWarrior 8 LED

## 4.1 Pin Descriptions KeyWarrior 8 xxx LED SSOP 48

Name	I/O	Type	Pins	Description
D+, D-	I/O	special	1, 2	USB differential data lines
PowerOn	I	internal Pull Up	3	Power Key input, pull high on power on
Data	O	CMOS	35	Data out to LED shift register
Clk	O	CMOS	14	Clock to LED shift register
Strb	O	CMOS	36	Strobe to LED shift register
/OE	O	CMOS	13	Driver enable for LED shift register
CapsLED	O	OD, 16mA	44	Drives Caps Lock LED, active low
NumLED	O	OD, 16mA	6	Drives Num Lock LED, active low
ScrollLED	O	OD, 16mA	43	Drives Scroll Lock LED, active low
X[7:0]	I	input, internal Pull Ups	7, 42, 8, 41, 9, 40, 10, 39	Matrix row lines. Inputs to controller
Y[7:0]	O	OD	17, 32, 18, 31, 19, 30, 20, 29	Matrix column lines. Periodically driven to low by the controller to scan the matrix.
SCL	O	CMOS	11	SCL line for external EEPROM (Flex, Op, Cell)
SDA	I/O	OD, internal Pull Up	5	SDA line for external EEPROM (Flex, Op, Cell)
NC	-	-	5, 11	Unused pin, do not connect (KeyWarrior 8LED)
NC	-	-	4, 12, 15, 16, 21, 22, 27, 28, 33, 34, 37, 38, 45, 46	Unused pin, do not connect
PullToGND	I		23	Used during manufacturing, connect to GND
GND		Power supply	24, 47	Ground
Vcc		Power supply	48	Supply voltage
XOut	O		26	On chip oscillator output
XIn	I		25	On chip oscillator input

# KeyWarrior 8 LED

## 4.2 Pin Descriptions

### D+, D-

Differential data lines of USB. Connect these signals direct to the USB cable or type B plug.

### PowerOn

Input for power key, also used internally during power up where it must be pulled high. Connect via 100K $\Omega$  to +5V and use a switch closing to Gnd if a power key is desired.

### CapsLED, NumLED, ScrolledLED

Open drain LED driver outputs. Each of these pins is capable of sinking 16mA max. to directly drive a LED indicating the Caps Lock, Number Lock and Scroll Lock status. Connect LEDs with appropriate resistors to +5V.

### X[0:7]

Matrix horizontal inputs. These eight lines are read by KeyWarrior to detect pressed keys. Internal pull up resistors are activated on device reset.

### Y[0:7]

Vertical matrix outputs. These open drain outputs are periodically pulled low to detect pressed keys. No internal or external pull up resistors.

### SCL (Flex/Operator/Cell only)

SCL line of the IIC to connect the external EEPROM.

### SDA (Flex/Operator/Cell only)

SDA line of the IIC to connect the external EEPROM.

### Data

Data output to the LED matrix shift registers.

### Clk

Clock output to the LED matrix shift registers

### Strb

Strobe output to latch the data in the LED shift registers

### /OE

Enable line to activate the drivers of the LED shift registers. The drivers must be inactive when /OE is high.

### /Pull to GND

This pin is used during production of the KeyWarrior chips, connect to GND.

### XOut, XIn

Connection for external oscillator. A 6MHz ceramic resonator may be connected here, no additional components are necessary. No crystal or three pin ceramic resonator may be used. The oscillator is optimized for ceramic resonators with two pins, other oscillating elements will result in unstable behaviour.

An external 6MHz clock may be connected to XIn, XOut has to be left floating in this case.

### GND

Power supply ground.

### Vcc

Supply voltage.

## 4.3 Flex, Operator, and Cell external EEPROM

The KeyWarrior Flex, Operator, and Cell controllers need an external EEPROM which contains the Master Translation Table.

In case of the KeyWarrior Flex controllers a 24C02 EEPROM is used (i.e. Fairchild NM24C02N). The KeyWarrior Operator and Cell require a 24C16 (i.e. Fairchild NM24C16N).

The SCL and SDA lines of the EEPROM need to be connected to the appropriate pins of the KeyWarrior controller. The A0, A1 and A2 pins of the 24C02 need to be pulled low.

A single PCB layout is capable of supporting Flex, Operator, and Cell controllers. The 24C02 and 24C16 are pin compatible and KeyWarrior Flex, Operator, and Cell are pin compatible as well.

KeyWarrior drives the IIC at about 100kHz.

The EEPROM may be either preprogrammed before insertion into the circuit or it can be programmed via the USB.

The utility software for downloading the Master Translation Table via USB is available for MacOS and Windows.

## 4.4 EEPROM potential problem

Though 24C02 and 24C16 chips originally were defined to have no signal on pin 7 we have found several manufacturers do use this pin for some write protect mechanism.

To avoid problems with these chips we recommend to tie pin 7 to ground, even though it will be not connected on most chips.

# KeyWarrior 8 LED

---

## 4.5 Designing the LED matrix

The design of the driver electronics for the LED matrix depends a lot on the type and use of the LEDs.

For simple indicator lights a design using shift registers with built in latches and drivers is sufficient. Refer to 9.3 for an application circuit using a MIC5895 (or MIC5891) and MIC5821 to drive the matrix with minimal parts.

The values of the resistors depend on the LEDs used. Make sure to limit the current through the LEDs to stay below the maximum allowed for your LED type.

The LED matrix is scanned at a frequency of 1kHz with a 1:8 ratio. Which means each individual LED will get current for 1msec every 8msec. So the current through the LED can be up to 8x the typical current but must be less than the maximum forward current.

Due to the multiplexing only 8 LEDs are on simultaneously at any time. Make sure that the combined current of eight LEDs plus the rest of the circuit does not exceed 500mA, or use an external power source to supply the LEDs.

More detailed information on how to handle LEDs in a matrix can be found in our Application Note "AN1: Using IO-Warrior with a LED matrix". The alternative circuits shown there for higher LED power can be used for KeyWarrior 8 LED as well.



# KeyWarrior 8 LED

## 5. Device Operation

KeyWarrior 8 LED registers as two logical devices (interfaces). The first interface is a standard HID keyboard, the second is a generic HID class interface which is used to control the LED matrix. KeyWarrior 8 LED requests 500mA off the USB, so it needs to be run on a self powered hub port or on a host port.

### 5.1 Power Up

Every time the supply voltage is applied KeyWarrior executes an internal reset sequence. All internal pull up resistors are disabled upon power up and will be activated during the internal reset sequence.

The PowerOn pin needs to be pulled high externally during power up to ensure proper operation.

### 5.2 Keyboard Scanning

KeyWarrior scans the keyboard matrix every  $t_{scan}$  by sequentially pulling one of the Y lines low and then reading the status at the X lines. When the scan matrix changes status and then remains stable for  $t_{debounce}$  KeyWarrior decodes the changes and generates scancodes.

### 5.3 Key Rollover

KeyWarrior supports true n-key rollover. All keys in the matrix may be pressed at the same time without KeyWarrior missing any code. However due to the phantom key effect it can not be guaranteed that combinations of many keys are properly reported (see 5.3.1).

USB has a limitation on how many keys can be reported at the same time. On USB any six keys plus all eight modifiers (GUI, Ctrl, Alt, Shift) may be pressed at the same time. If more than six ordinary keys are pressed an error state is reported. So USB has a 6-key plus modifiers rollover.

#### 5.3.1 Phantom Keys

Phantom keys do occur when three or more keys are pressed in a combination that leads to the matrix reading like a fourth key has been pressed.

To avoid phantom keys diodes may be added to the keys. If diodes are used they have to be put in series with the key switches. The cathodes have to be connected to the Y lines and anodes to X lines.

It is highly recommended to place all modifier keys on a single row or column and put diodes on

all of them.

### 5.4 Protocol Details

KeyWarrior works as a HID compliant keyboard using boot protocol. The country code is 0 for not localized hardware, which allows to use a single version of the chip for all international keyboard layouts. Usage codes are defined for 0 to 164, which include the Power key and the = sign in the keypad, as well as the compose keys for Asian languages and several special keys that may or may not be supported by individual operating systems.

### 5.5 Controlling the LED matrix

The LED matrix is controlled via the second interface of the KeyWarrior 8 LED. An interface on USB is a logical function in a USB device.

Setting the status of the LED matrix is done by sending a report with 8 bytes containing the LED data to interface 1. A "1" in that array of 64 bits corresponds to a lit LED. The bytes correspond to the rows, the bits to the columns in the LED matrix.

The current status of the LED matrix is constantly transmitted back via interface 1 using the interrupt in endpoint 2.

# KeyWarrior 8 LED

## 6. Custom Scancode Tables

KeyWarrior uses a single table to translate the matrix coordinates to USB usage codes. This table is customer specified, it is called the "Master Translation Table".

For information on generating the Master Translation Table please refer to the document "Creating Custom KeyWarrior Scancode Tables".

### 6.1 Function Shift Keys

KeyWarrior allows the definition of one or two function shift keys. If this key is pressed KeyWarrior uses a second or third translation table to convert matrix coordinates to USB usage codes.

This allows a small keyboard to generate all functions of a full sized keyboard.

The function shift key may be on any coordinate in the matrix, it is assigned by placing a special code in the corresponding table position.

### 6.2 Programming a Flex, Operator, or Cell Controller

KeyWarrior Flex, Operator, and Commander controllers may be programmed via the USB from a Macintosh or Windows PC. A utility program reads the assembly source file for a Master Translation Table and transmits it to the KeyWarrior Flex, Operator, or Cell controller.

The format of the file for Flex controllers is exactly the same as the file being used to generate the data for preprogrammed versions of the KeyWarrior chips. There are no preprogrammed versions of KeyWarrior that are able to offer the function of the Operator and Cell controllers.

Alternatively the external EEPROM may be programmed in any appropriate device programmer and then inserted into the circuit.

KeyWarrior Flex, Operator and Cell are not intended for applications which provide keyboard function programming options for the end user.

### 6.3 KeyWarrior Operator Key Definitions

The KeyWarrior Operator controllers allow to program up to 8 key functions onto a single key.

Any unused key function for any individual key must be programmed as \$00. A \$00 in the Master Translation Table will generate no keycode.

Multiple key functions programmed onto a single key will activate in the sequence as programmed. They do stay active ("pressed") as long as the physical key is pressed.

This limits the macros to sequences in which multiple keys are pressed at the same time. It is not possible to program multiple keystrokes of the same key function onto one physical key.

### 6.4 KeyWarrior 8 Cell LED Key Definitions

The KeyWarrior 8 Cell LED has two different types of keys. All keys in the rows Y0..Y5 (48 keys in total) do behave like keys on the Operator chips. That means each one of these keys can send up to eight codes.

There are two FN keys on the KeyWarrior 8 Cell which allows three function levels for the keys in Rows Y0..Y5.

All keys in rows Y6 and Y7 (16 keys total) do behave similar to the keypad of a cellular phone. For each of these keys four codes are programmed. The first of these codes is used when no FN key is pressed.

If any of the FN keys is pressed these 16 keys work in a cycling mode. Holding any FN key plus pressing a "Cell-Key" does send the second code for that key. Pressing the same key again without releasing the FN key does send first a backspace code and then the third code, then backspace and the fourth code, backspace and the second code and so on.

So this mode allows you to step through three different codes for each of these "Cell-Keys".

Every time the FN key is released, or a different Cell-Key is pressed no backspace will be send prior to the next code.

This allows to build a keyboard with full alpha numeric capability with very few keys.

# KeyWarrior 8 LED

## 7. DC Characteristics

	Parameter	Min	Max	Units	Remarks
V <sub>cc</sub>	Operating Voltage	4.35	5.25	V	
I <sub>cc</sub>	Operating Supply Current		40	mA	
I <sub>sb</sub>	Suspend mode current		20	μA	Oscillator off
I <sub>ol</sub>	Sink current on LED pins	7.2	16.5	mA	V <sub>out</sub> = 1.0V
<b>USB Interface</b>					
V <sub>oh</sub>	Static output high	2.8	3.6	V	15kΩ±5% to GND
V <sub>ol</sub>	Static output low		0.3	V	
V <sub>di</sub>	Differential Input sensitivity	0.2		V	(D+)-(D-)
V <sub>cm</sub>	Differential Input common Mode Range	0.8	2.5	V	
V <sub>se</sub>	Single Ended Transceiver Threshold	0.8	2.0	V	
C <sub>in</sub>	Transceiver capacitance		20	pF	
I <sub>jo</sub>	Hi-Z State Data Line Leakage	-10	10	μA	0V < V <sub>in</sub> < 3.3V
R <sub>pu</sub>	Bus Pull-up resistance	7.35	7.65	kΩ	7.5kΩ±2%
R <sub>pd</sub>	Bus Pull-down resistance	14.25	15.75	kΩ	15kΩ±5%

## 7.1 AC Characteristics

	Parameter	Min	Max	Units	Remarks
t <sub>cyc</sub>	input clock cycle time	165.0	168.3	ns	
t <sub>ch</sub>	Clock high time	0.45t <sub>cyc</sub>		ns	
t <sub>cl</sub>	Clock low time	0.45t <sub>cyc</sub>		ns	
<b>USB Driver Characteristics</b>					
t <sub>r</sub>	Transition rise time	75		ns	C <sub>Load</sub> = 50pF
t <sub>r</sub>	Transition rise time		300	ns	C <sub>Load</sub> = 350pF
t <sub>f</sub>	Transition fall time	75		ns	C <sub>Load</sub> = 50pF
t <sub>f</sub>	Transition fall time		300	ns	C <sub>Load</sub> = 350pF
t <sub>rfm</sub>	Rise/Fall Time matching	80	120	%	
V <sub>crs</sub>	Output signal crossover voltage	1.3	2.0	V	
<b>USB Data Timing</b>					
t <sub>drate</sub>	Low Speed Data Rate	1.4777	1.5225	MBit/s	
t <sub>djr1</sub>	Receiver data jitter tolerance	-75	75	ns	To next transition
t <sub>djr2</sub>	Receiver data jitter tolerance	-45	45	ns	For paired transitions
t <sub>deop</sub>	Differential to EOP transition skew	-40	100	ns	
t <sub>eoпр1</sub>	EOP width at receiver	165		ns	Rejects as EOP
t <sub>eoпр2</sub>	EOP width at receiver	675		ns	Accepts as EOP
t <sub>eoпрt</sub>	Source EOP width	1.25	1.50	μs	
t <sub>udj1</sub>	Differential driver jitter	-95	95	ns	To next transition
t <sub>udj2</sub>	Differential driver jitter	-150	150	ns	To paired transition
<b>Keyboard Matrix Scan Timing</b>					
t <sub>scan</sub>	Scanning interval	4*		ms	
t <sub>scansu</sub>	Matrix drive to read setup time	typ. 40*		μs	
t <sub>debounce</sub>	Debounce time	3x t <sub>scan</sub> *		ms	

\*) A version with fast scanning to better suit rubber dome keyboards is available. In this case t<sub>scan</sub> = 1ms, t<sub>debounce</sub> = 2x t<sub>scan</sub> and t<sub>scansu</sub> = 10μs

---

## 7.2 Absolute Maximum Ratings

Storage Temperature	-65°C to +150°C
Ambient Operating Temperature	0°C to +70°C
Supply Voltage on Vcc relative to Vss	-0.5V to +7.0V
DC Input Voltage	-0.5V + Vcc + 0.5V
Max. Output Current into any Pin	60mA
Power Dissipation	300mW
Static Discharge Voltage	>2000V
Latch-up Current	>200mA

# KeyWarrior 8 LED

## 8. Ordering Information

Partname	Order Code	Description	Package
KeyWarrior 8 LED	custom	Preprogrammed, customer specific part	PDIP40
KeyWarrior 8 LED	custom	Preprogrammed, customer specific part	SSOP48
KeyWarrior 8 Flex LED	KW8FXLED-P	External EEPROM, single code per key	PDIP40
KeyWarrior 8 Flex LED	KW8FXLED-S	External EEPROM, single code per key	SSOP48
KeyWarrior 8 Operator LED	KW8OPLIED-P	External EEPROM, macros	PDIP40
KeyWarrior 8 Operator LED	KW8OPLIED-S	External EEPROM, macros	SSOP48
KeyWarrior 8 Cell LED	KW8CELLED-P	Cellphone mode, external EEPROM	DIL40
KeyWarrior 8 Cell LED	KW8CELLED-S	Cellphone mode, external EEPROM	SSOP48

Preprogrammed KeyWarrior chips are customized to fit the specific keyboard they should drive. For ordering KeyWarrior chips the customer needs to supply the matrix information preferably already formatted as a master translation table.

Code Mercenaries will assign a part number to any specific chip so it can be identified for future orders.

Preprogrammed chips may be subject to minimum order quantities and setup charges, please contact sales for details.

KeyWarrior Flex, Operator, and Cell controllers are configured for the specific keyboard by loading the Master Translation Table into an external EEPROM. This can be done by the customer.

KeyWarrior Flex, Operator, and Cell controllers are standard parts that may be purchased without any setup costs or minimum order quantities.

### 8.1 Shipping info

DIL40 chips do come in tubes of 10 each. SSOP48 chips come in tubes of 30 each.

To assure the safest handling we recommend that you order in multiples of full tubes.

### 8.2 DIL 40 going obsolete

The DIL40 package is going to be discontinued. It is not recommended to use it for any new designs, except for small volumes and short term production. DIL40 will be available for prototyping purposes as long as possible.

### 8.3 USB VendorID and ProductID

By default all KeyWarrior chips are shipped with the USB VendorID of Code Mercenaries (\$7C0 or decimal 1984).

The ProductID will be assigned by Code Mercenaries.

On request chips can be equipped with the customers VendorID and ProductID. VendorIDs can be obtained from the USB Implementers Forum <[www.usb.org](http://www.usb.org)>

KeyWarrior Flex, Operator, and Cell chips are always shipped with a fixed ProductID and the Code Mercenaries VendorID.

Following are the ProductIDs:

KeyWarrior 8 Flex LED	\$0140
KeyWarrior 8 Operator LED	\$0150
KeyWarrior 8 Cell LED	\$0151

ProductIDs are independent of the package type.

# KeyWarrior 8 LED

## 9. Typical Application for KeyWarrior 8 Flex LED, Controller Part, SSOP48

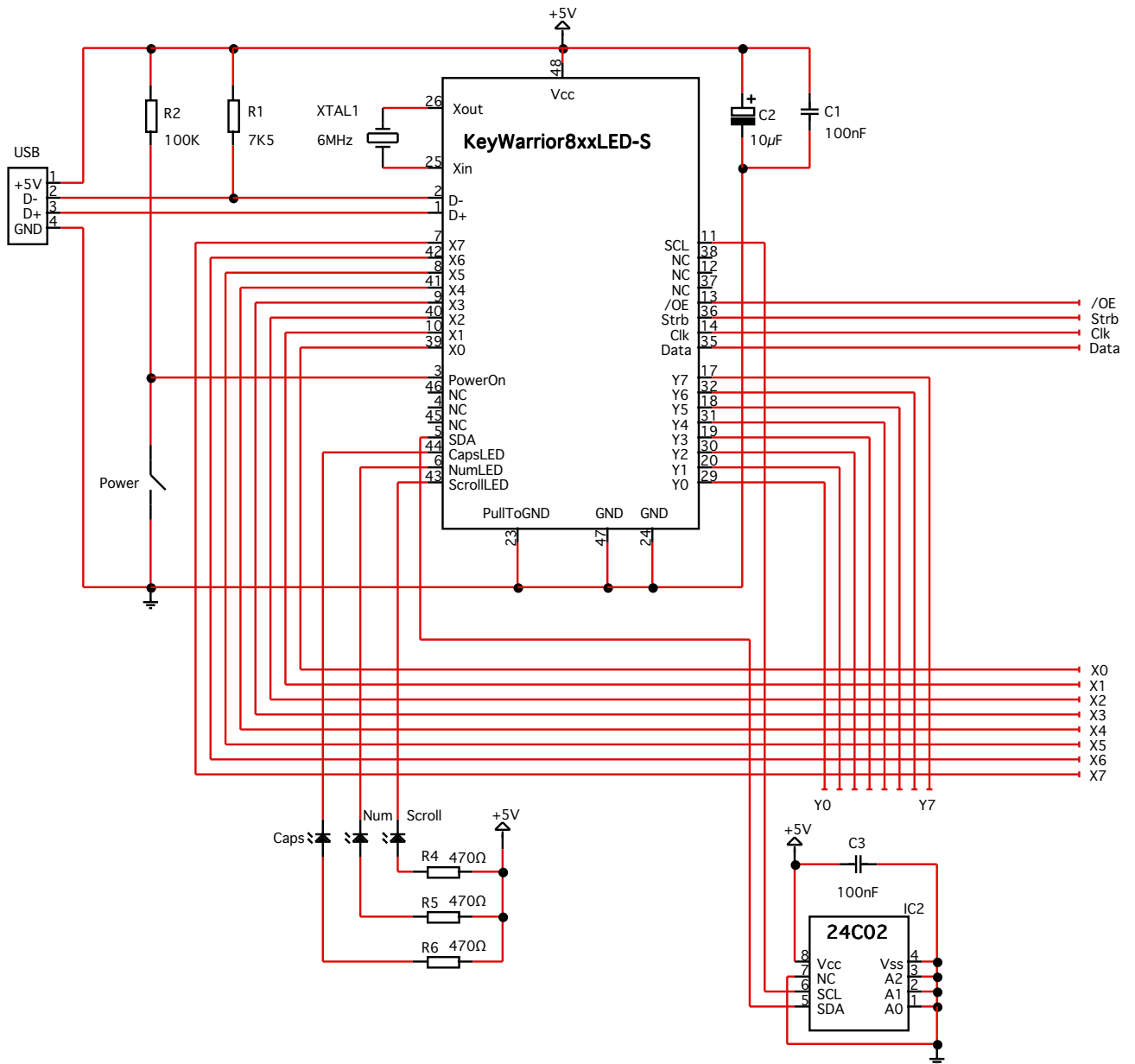

<b>Circuit:</b> KeyWarrior8FlexLED		 Code Mercenaries		
<b>Version:</b> 1.0				
<b>Date:</b> 20.7.2007				
<b>Drawn by:</b>				
<b>Function:</b>				
<b>Page:</b>				
Rev.	Date	By	Change	Sign.

# KeyWarrior 8 LED

## 9.1 Typical Application for KeyWarrior 8 Operator/Cell LED, Controller Part, SSOP48

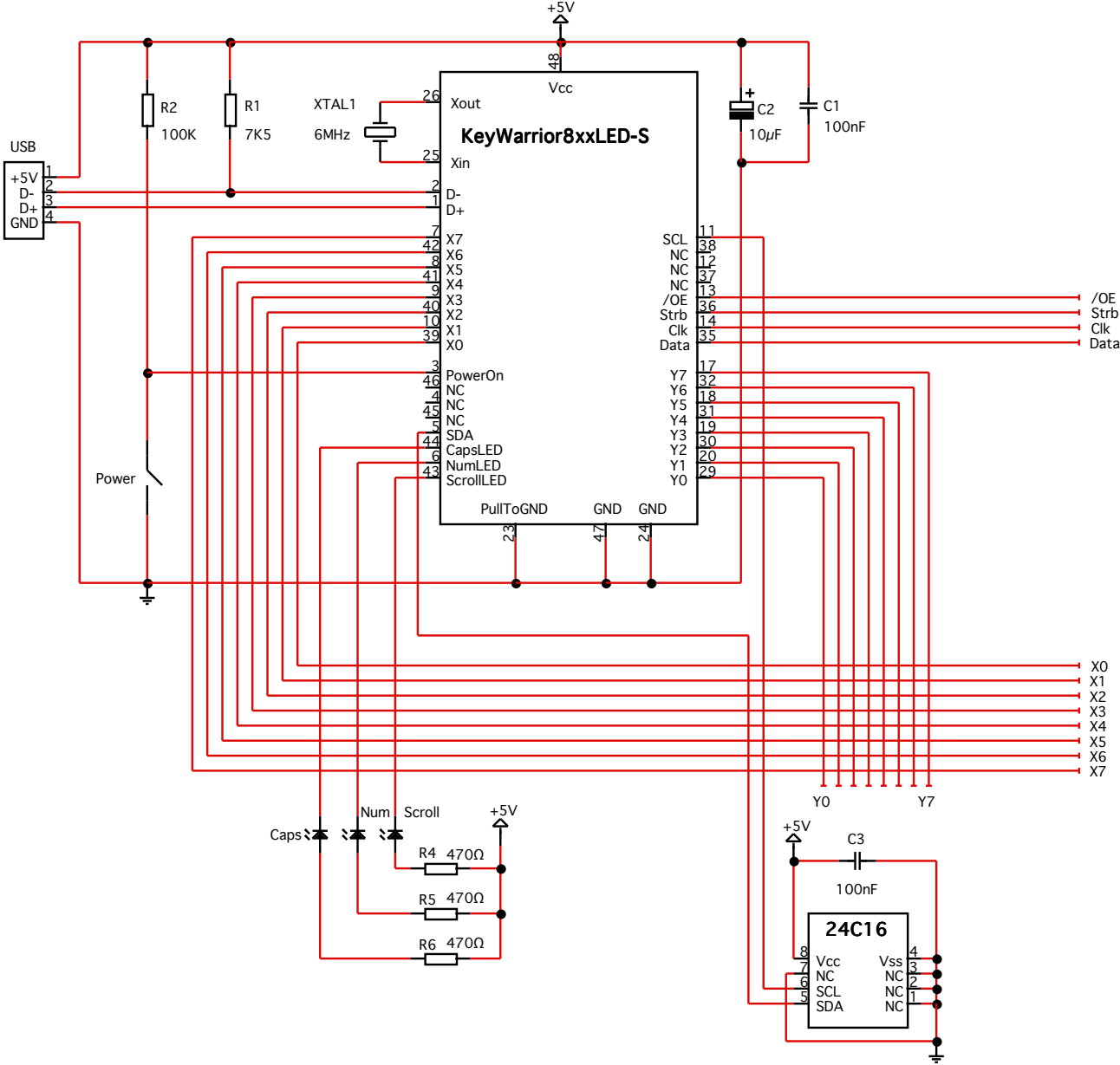

<b>Circuit:</b> KeyWarrior8xxLED		 Code Mercenaries		
<b>Version:</b> 1.0				
<b>Date:</b> 20.7.2007				
<b>Drawn by:</b>				
<b>Function:</b>				
<b>Page:</b>				
<b>Rev.</b>	<b>Date</b>	<b>By</b>	<b>Change</b>	<b>Sign.</b>

# KeyWarrior 8 LED

## 9.2 Typical Application for KeyWarrior 8 LED, Controller Part, SSOP48

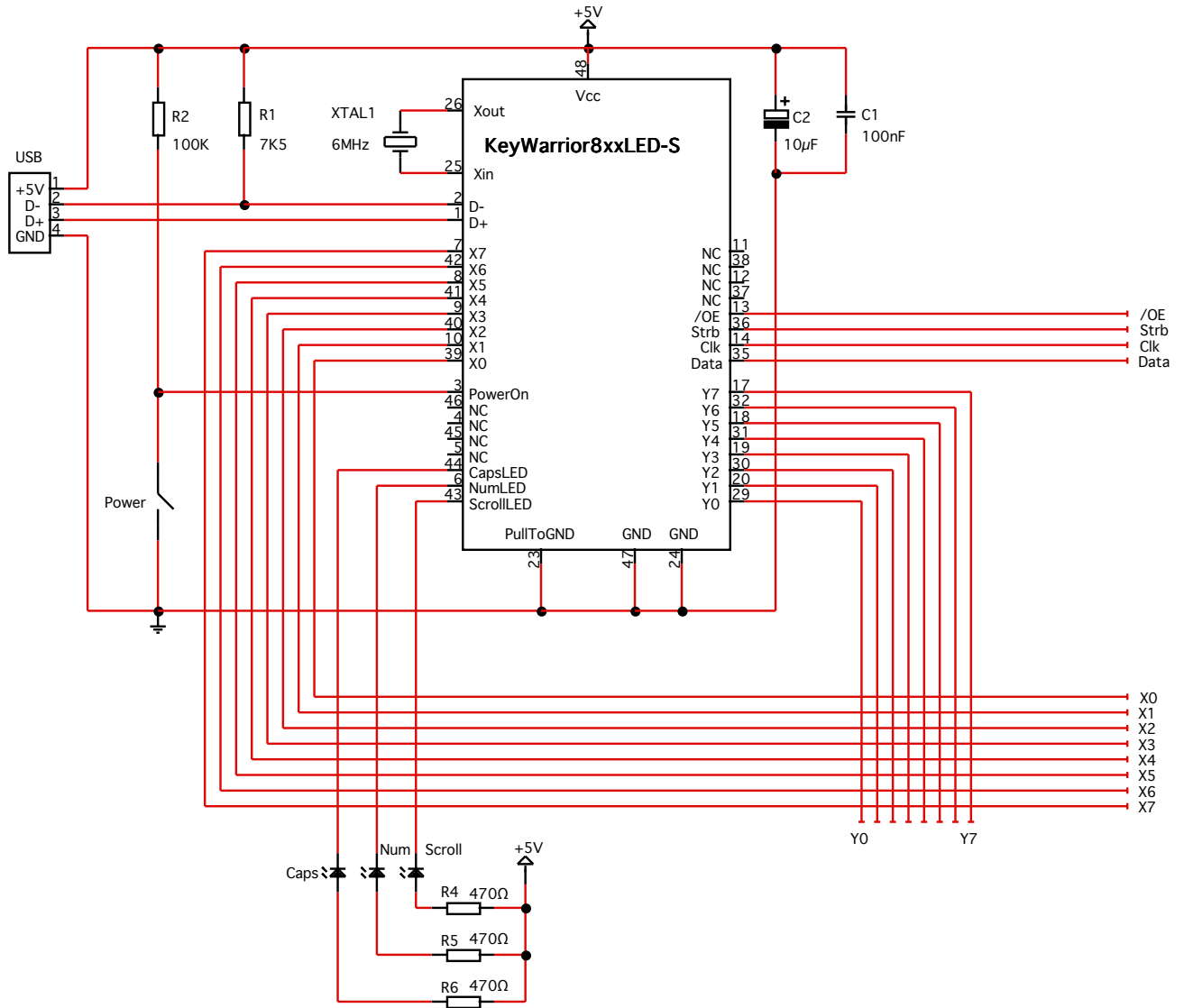

<b>Circuit:</b> KeyWarrior8LED		 Code Mercenaries		
<b>Version:</b> 1.0				
<b>Date:</b> 20.7.2007				
<b>Drawn by:</b>				
<b>Function:</b>				
<b>Page:</b>				
Rev.	Date	By	Change	Sign.



## 9.3 Typical Application for LED matrix part

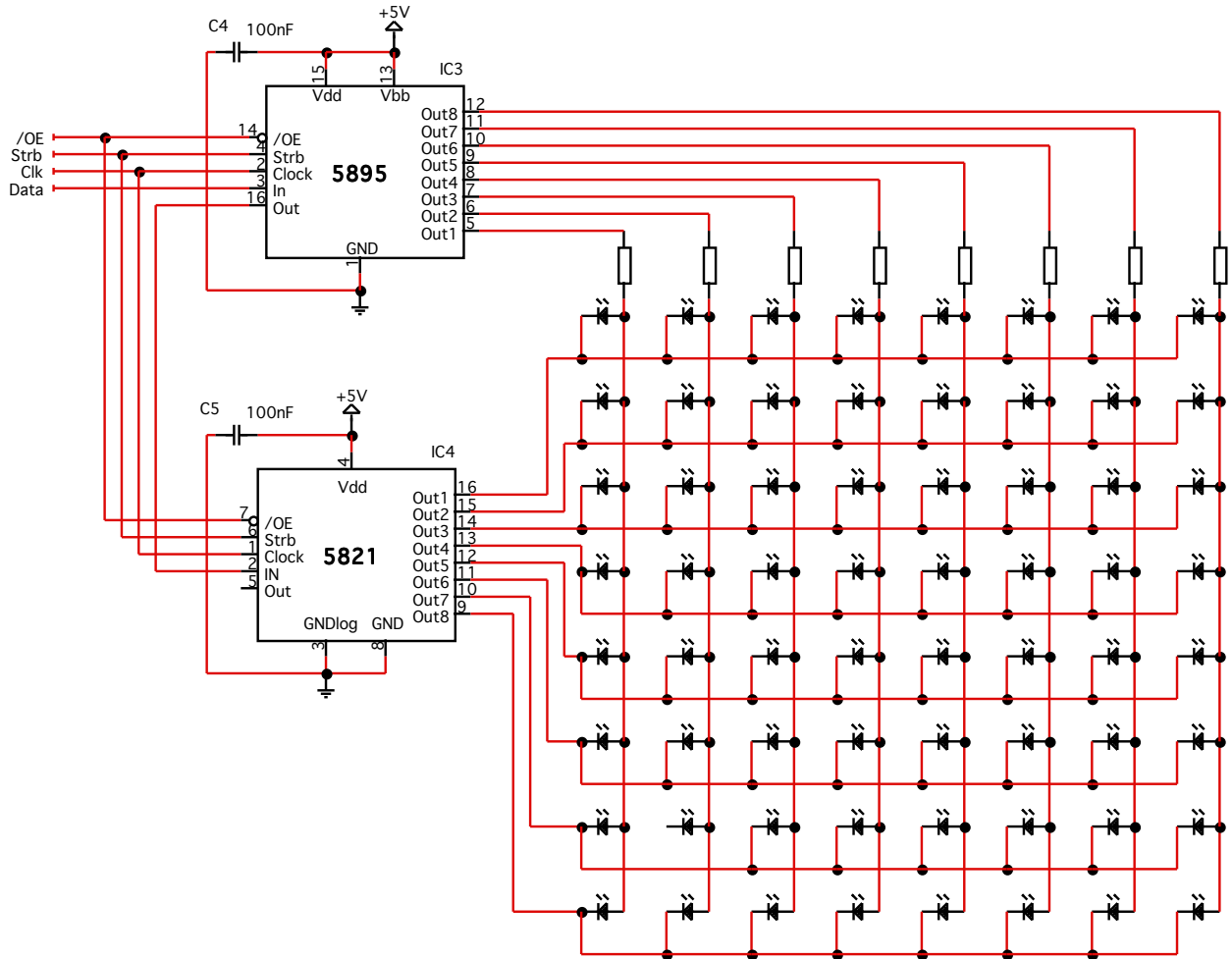

<b>Circuit:</b> KW8LED Matrix part		 Code Mercenaries		
<b>Version:</b> 1.0				
<b>Date:</b> 20.7.2007				
<b>Drawn by:</b>				
<b>Function:</b>				
<b>Page:</b>				
Rev.	Date	By	Change	Sign.

## 10. Package Dimensions

### 40 Pin PDIP

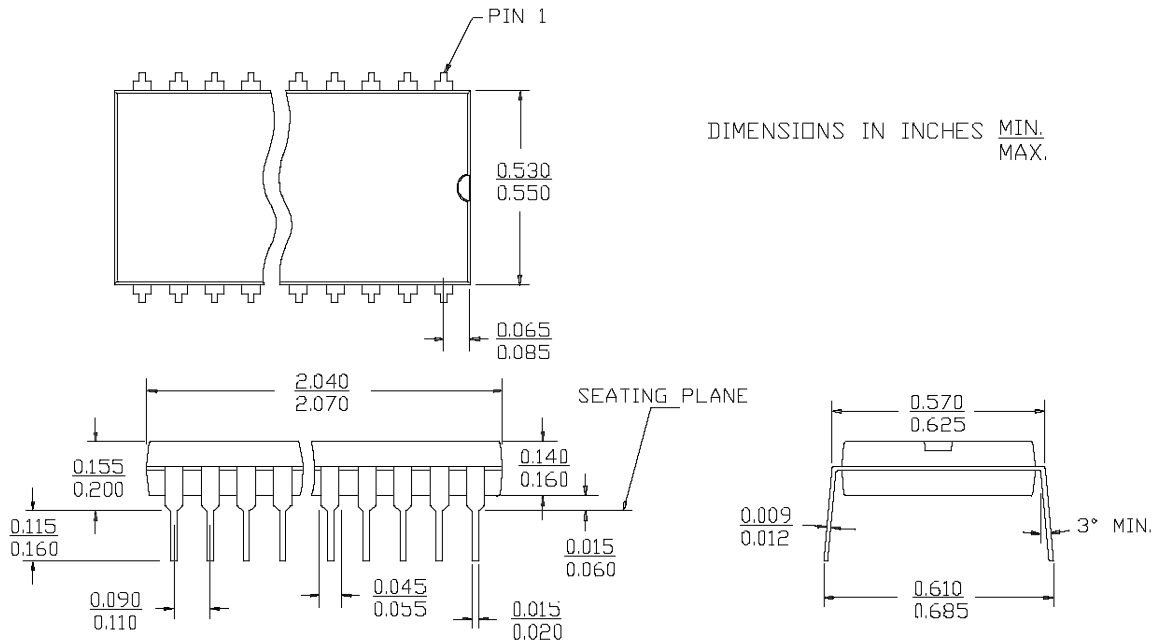

### 48 Pin SSOP

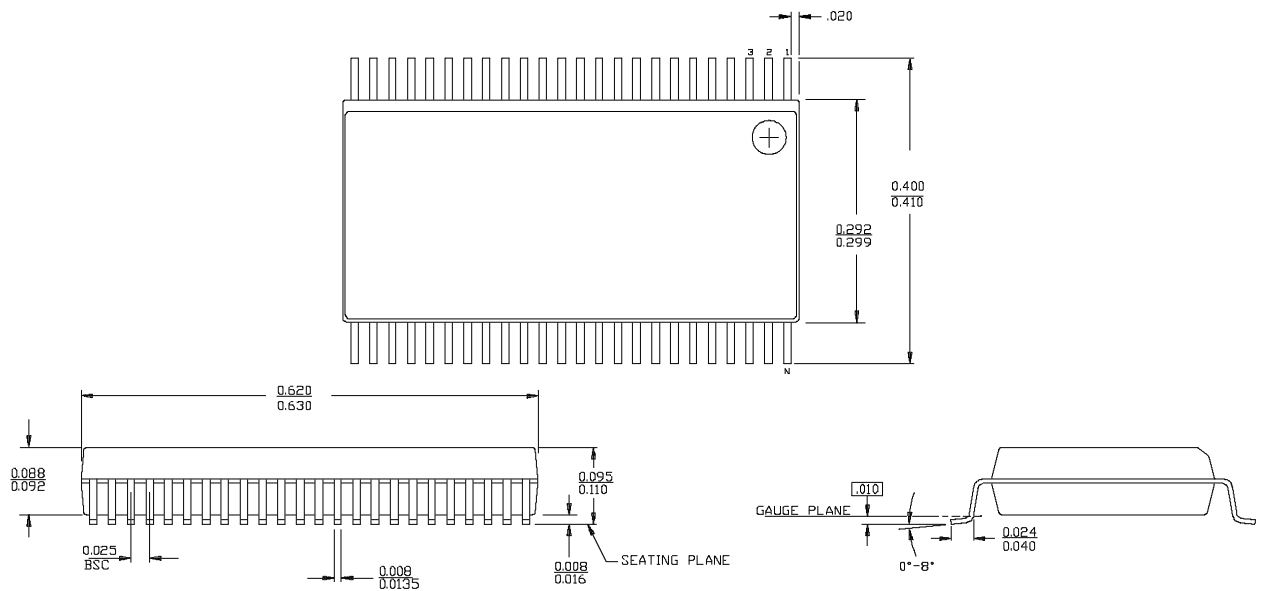

# KeyWarrior 8 LED

## 11. ESD Considerations

KeyWarrior has an internal ESD protection to withstand discharges of more than 2000V without permanent damage. However ESD may disrupt normal operation of the chip and cause it to exhibit erratic behaviour.

For the typical office environment the 2000V protection is normally sufficient. Though for industrial use additional measures may be necessary.

When adding ESD protection to the signals special care must be taken on the USB signal lines. The USB has very low tolerance for additional resistance or capacitance introduced on the USB differential signals.

### 11.1 EMC Considerations

KeyWarrior uses relatively low power levels and so it causes few EMC problems. The LED matrix though may generate some emissions if not laid out carefully.

To avoid any EMC problems the following rules should followed:

- Keep the PCB traces from the resonator to the chip pins as short as possible.
- Put a 100nF ceramic capacitor right next to the power supply pins and make sure the PCB traces between the chips power pins and the capacitor are as short as possible.
- Run the power supply lines first to the capacitor, then to the chip.
- Make the matrix lines only as long as absolutely necessary.

Adding a ferrite bead to the +5V and ground power supply lines is advisable.

## 12. Revision History

This is a supplemental data sheet to the KeyWarrior data sheet. Please refer to the main data sheet for the revision history.

V1.1.0.5 is the initial release version of the KeyWarrior 8 LED family.

## 13. RoHS compatibility

RoHS compatible parts are indicated by a "R" being appended to the version number.

I.e. a KeyWarrior 8 Flex LED in SSOP48 package will have a marking as follows if it is RoHS compatible:

KW8FXLED-S

V1.1.0.5R

## Legal Stuff

This document is ©1999-2013 by Code Mercenaries Hard- und Software GmbH.

The information contained herein is subject to change without notice. Code Mercenaries makes no claims as to the completeness or correctness of the information contained in this document.

Code Mercenaries assumes no responsibility for the use of any circuitry other than circuitry embodied in a Code Mercenaries product. Nor does it convey or imply any license under patent or other rights.

Code Mercenaries products may not be used in any medical apparatus or other technical products that are critical for the functioning of lifesaving or supporting systems. We define these systems as such that in the case of failure may lead to the death or injury of a person. Incorporation in such a system requires the explicit written permission of the president of Code Mercenaries.

Trademarks used in this document are properties of their respective owners.

Code Mercenaries  
 Hard- und Software GmbH  
 Karl-Marx-Str. 147a  
 12529 Schönefeld / OT Grossziethen  
 Germany  
 Tel: +49-3379-20509-20  
 Fax: +49-33790-20509-30  
 Mail: support@codemercs.com  
 Web: www.codemercs.com

HRB 9868 CB  
 Geschäftsführer: Guido Körber, Christian Lucht